

TimeKeeper™ F-Series Users manual

COPYRIGHT: 2000-2013 (C) by Alzatex, Inc.

This software package is installed on many of the Alzatex **TimeKeeper™**, products including timers and displays with displays with 0.56" high digits to 36" high digits. The displays may have 1 to 16 digits and may have zero to 24 buttons. All models have remote inputs and/or a serial communication port. Optional remote button modules may be used to control the timer/display.

Applications

- Production Monitoring and Production Control.
- Sporting Events of all kinds.
- Take-a-number Systems.
- Days since last accident display.
- Count down clocks.
- Public Speaking events.
- Master Clock Systems.
- And many others.



TMR221B TimeKeeper™ with 8 buttons, knob and LED display.



KP219A-RF2 wireless keypad with 18 buttons and a knob.



KP215A Remote Keypad with 8 buttons and a knob.



DSP606S Large LED display on a tripod.

Features

This software supports the following features. Not all models will have all the features. See the list below describing each of the individual models and the features supported.

- **Time of Day Clock.**

The time of day clock displays hours, minutes and seconds in either military time or 12 hour AM/PM format. Also, minutes and seconds only can be displayed.

- **Up/Down Count Timer.**

The timer counts from 00.00 to 99.59 minutes, or from 00:00:00 to 99:59:59 hours. This timer can count seconds and tenths or hundredths of seconds 00.00.00 to 99.99.99. The timer can be changed on-the-fly from time remaining to time elapsed, while the timer is running. The timer has built in Green-Yellow-Red programmable warning times. A beeper may be sounded at each of the warning times, at red only or be turned off.

- **Programmable Presets.**

The timer can have up to 8 programmable presets. The values stored include the timer preset time, green and yellow warning times, beeper mode, count up/down and run/stop status. The presets are stored in non-volatile memory, so they are remembered even if the power is off and the battery is removed. The 8th preset is the power up preset.

- **Remote Display.**

This unit can operate as a remote display slave to another Alzatex TimeKeeper™, or may be remotely controlled by a computer, Crestron, AMX system or PLC.

- **Take-A-Turn System.**

This unit may also be used as a take-A-Turn system for NOW SERVING the next customer. The unit can be configured with NEXT, PREVIOUS and RESET buttons. The unit also has remote inputs for external buttons. Range 0 to 999,999.

- **Tallye Counter.**

Wigits, machine operations, game scores or anything you may want to count may be counted. The unit can be configured with UP, DOWN and RESET buttons. The unit also has remote inputs for external buttons or for connecting to a machine for automatic operation. Range 0 to 999,999.

- **Remote Terminal.**

This unit may be operated as a terminal to a PLC or other controller. Button presses from the Timekeeper™ are sent to the PLC. The PLC sends display commands to the Timekeeper™.

- **Serial data port.**

Some models have RJ45 modular phone jacks on the rear of the unit. One jack is marked TX422 to transmit serial data and another jack marked RX422 to receive serial data. Standard network cable is used. The Blue pair sends data in RS422 format. The other pairs are used to send DC power from one device to another.

Some models have RJ11 modular phone jacks on the rear of the unit. One jack is marked TX to transmit serial data and another jack marked RX to receive serial data. Four conductor modular phone cord is used to send data, power and SYNC from one unit to another.

A standard RJ11 or RJ45 jack on the rear of the unit permits the timer to be connected to other timers and /or displays, to remote displays or to a Crestron, AMX system, PC serial port or any other device having a RS232C serial port. The baud rate is user-programmable from 1200 to 115,200.

- **Display Dimming.**

The brightness of Remote displays may be controlled from the Timekeeper™. This feature is useful for daytime/nighttime use. The display dimming feature is available on specific models only.

Timer reference guide.

The TimeKeeper™™ Count Up/Down timer with Clock The TimeKeeper™™ Count Up/Down timer with Clock and Presets

Timer Mode (hh:mm:ss)

- Press the **Reset** button to select timer mode.
- Turn the **Knob** to set desired time. The **Select** button selects between setting hours, minutes and seconds.
- Press the **Start/Stop** button to start the timer.

The **Mode** button selects between count-up and count-down modes. You may change between count-up and count-down modes while the timer is running. In count-down mode, the timer stops when it reaches zero. In count-up mode, the timer keeps running when the preset time is reached.

Press and hold the **Mode** button to select the desired beeper mode.

User Programmable Presets

- Setup the timer preset time to the desired time.
- Set the Green and Yellow Warning times the way you want them.
- Also, select the desired count up/down mode and beeper mode.
- If you want the preset to start the timer automatically, start the timer running.
- Press and hold the desired **Preset** button to save the timer preset time, Yellow Warning and Yellow Blink times, timer count up/down mode, beeper mode, special timer modes, timer run status, tally counter preset value, and tally counter scale factor. When the display changes, the settings are stored.
- To activate the **Preset**, a single button press will set the timer to the exact conditions that were saved.

Power Up Presets

- Setup the timer preset time to the desired time.
- Set the green and yellow warning times the way you want them.
- Also, select the desired count up/down mode and beeper mode.
- Press and hold the **START** button until the display changes. The display will show “**FF**”.
- Press and hold the **RESET** button until the display blinks to save the timer preset time, green and yellow warning times, timer count up/down mode, beeper mode and special timer modes. When the display changes, the settings are stored.
- The next time the unit is powered up, these settings will be restored.
- To delete the power up presets, set the hours, minutes and seconds to 00:00:00.
- Press and hold the **START** button until the display changes. The display will show “**FF**”.
- Press and hold the **RESET** button until the display blinks. The next time the unit is powered up, the factory default settings will be loaded.

Clock Mode

- Press the **Clock** button to select clock mode.
- The **Clock** or **Select** buttons select displaying 12 hour time, military time or seconds. In 12 hour mode, the PM LED will be on for PM and off for AM.

Press and hold the **Clock** button to enter set time mode.

- Turn the **Knob** to set the hours.
- Press the **Clock** button again.
- Turn the **Knob** to set the minutes.
- Press the **Clock** button again to return to normal display, or other available settings, like seconds.

Special Timer Modes

While in the count down mode, when the timer reaches zero, it stops. Two other special timer modes are available. Press and hold the **Start** button until the display changes. Turn the **Knob** to select the desired mode.

- Mode 0: (**default**) Stop when the timer reaches zero. In this mode, the timer stops when the elapsed time reaches zero.
- Mode 1: Red blink on timer zero. The red indicator blinks until the timer is reset.
- Mode 2: Auto-Restart mode. In this mode, the timer automatically restarts counting down from the preset value each time the timer reaches zero. The Auto-Restart mode works in both count up and count down modes. The count up mode uses the count down timer preset time to determine when to reset the count up timer back to zero and restart.
- Mode 3: Change to count up when the timer reaches zero. In this mode, the timer changes to the count up mode and starts counting up when the timer reaches zero.

Beeper Modes

The Timekeeper™ has five beeper modes: Single beep; Beep at each of the warning times; Pulsing beep until reset; steady beep until reset, and beeper disabled. Press and hold the **Mode** button until the display changes. Turn the **Knob** to select the desired beeper mode.

- Mode 0: Beeper off.
- Mode 1: A single beep when the timer reaches zero.
- Mode 2: Beep at the warning times and at zero.
- Mode 3: Continuous pulsing beep when the timer reaches zero. Pressing the **Reset** button stops the beep.
- Mode 4: Continuous steady beep when the timer reaches zero. Pressing the **Reset** button stops the beep.
- Mode 5: Not used. (Used with production TAKT timer only. See separate manual)
- Mode 6: Not used. (Used with production TAKT timer only. See separate manual)
- Mode 7: Beep when the timer is started. Also beeps when the timer reaches zero.

Red-Yellow-Green Display

- The **Green** lamp comes on when the timer is started and remains on until the warning time is reached.
- When the **Yellow** blink time is reached, the **Green** lamp goes off and the **Yellow** lamp blinks on and off every second. The default **Yellow** blink time is 2 minutes (see table below) before the count down timer reaches zero.
- When the **Yellow** warning time is reached, the **Yellow** lamp remains on steadily. The default **Yellow** steady time is 1 minute (see table below) before the count down timer reaches zero. Note that the **yellow** steady and **yellow** blink times may occur in any order depending on the programmed setting. If they are set to the same time, the **yellow** steady takes precedence.
- When the timer reaches zero, the **Red** lamp comes on and the **Yellow** lamp goes off. In the count down mode, the timer stops when the **Red** lamp turns on. In the count up mode, the timer keeps running after the lamp turns **Red**.
- Press the **Reset** button on the TimeKeeper™ to turn off the **Red** lamp.
you can set any desired yellow warning time. The green warning time will always be twice the yellow warning time.

Setting minutes & seconds for the Blink Time

- Press and hold the **Select** button until the screen reads “*blnk*” and then release the **Select** button. The current blink time setting will appear.
- Turn the **Knob** to the minute(s) setting desired.
- Tap the **Select** button once and turn the knob to add seconds. (Tapping the **Select** button now toggles between setting minutes and seconds.)
- Tap the **Reset** button to return to the count-down time.

Setting minutes & seconds for the Warning Time

- Press and hold the **Select** button until the screen reads “*blnk*.” Release the **Select** button and press and hold it again until the screen reads “*-lArm*.” The current warning time setting will appear.
- Turn the **Knob** to the minute(s) setting desired.
- Tap the **Select** button once and turn the knob to add seconds.
- Tap the **Reset** button to return to the count-down time.

NOTE: Different models present the warning times in different ways, but the basic behavior is the same, typically displaying different colors for the warnings.

Total Time	Yellow Blink	Yellow Steady	Red
0:00-0:29	0:02	0:01	0:00
0:30-0:59	0:20	0:10	0:00
1:00-1:59	0:30	0:15	0:00
2:00-3:59	1:00	0:30	0:00
4:00-99:59	2:00	1:00	0:00

Timer Variations

Not all timer models can perform all the functions described in this document. Most timer models have a knob rather than up/down buttons to set the time. Not all timer models have a beeper. Some minor variations exist between the units, such as one unit has a **Start** button and another may have a **Start/Stop** button.

- Count Down Timers have **Start** and **Reset** buttons.
- Count Down Timers with Clock have **Start**, **Reset** and **Clock** buttons.
- Count Up/Down Timers have **Start**, **Reset**, **Mode** and **Select** buttons.
- Count Up/Down Timers with Clock have **Start**, **Reset**, **Mode**, **Select**, and **Clock** buttons.
- Count Up/Down Timers with Presets have **Start**, **Reset**, **Mode**, **Select**, and one or more **Preset** buttons.
- Count Up/Down Timers with Clock and Presets have **Start**, **Reset**, **Mode**, **Select**, **Clock** and one or more **Preset** buttons.
- Remote buttons can control the timers, and those remote buttons may have similar names but different functions, such as buttons named “Start/Stop”, “Start/Pause”, or “Start”.

Timer Models

This manual supports the following Timekeeper™ models.

- DSP017C-SM – Timer with four 0.56” high solid segment digits (surface mount; 4 buttons).
- DSP017C-FM – Timer with four 0.56” high solid segment digits (flush mount; 4 buttons).
- DSP221F-SM3, SM4, SM5, SM8, SM9 – Timer with four 0.56” high solid segment digits (surface mount; 3,4,5,8,9 buttons).
- DSP221F-FM3, FM4, FM5, FM8 – Timer with four 0.56” high solid segment digits (flush mount; 3,4,5,8 buttons).
- DSA216B16 – Timer with six 0.54” high solid segment alpha-numeric digits.
- DSA256A – Timer with six 2-1/3” high solid segment alpha-numeric digits.
- DSP106A – Timer with six 1” high solid segment digits.
- DSP252E, DSP254E, DSP256E – Timer with 2-1/3” high solid segment digits.
- DSP252E-TRI, DSP254E-TRI, DSP256E-TRI – Timer with 2-1/3” high tri-color solid segment digits.
- DSP402B, DSP404B, DSP406B, DSP408B – Timer with 4” high individual LED digits.
- DSP452A, DSP454A, DSP456A – Timer with 4” solid segment digits.
- DSP502F, DSP503F, DSP504F, DSP505F, DSP506F, DSP508F – Timer with 5” high individual LED digits.
- DSP602F, DSP604F, DSP606F, DSP608F – Timer with 6” high individual LED digits.
- DSP702F, DSP703F, DSP704F, DSP706F, DSP708F – Timer with 7” high individual LED digits.
- DSP1002F, DSP1003F, DSP1004F, DSP1005F, DSP1006F, DSP1008F – Timer with 10” high individual LED digits.

Any of the units may have one or more optional buttons, as well as remote triggers/buttons. Some of the remote keypads are listed below.

- KP212A – Keypad with 4 buttons, an RS422 jack and 2 optically isolated inputs in surface mount metal enclosure.
- KP213A – Keypad with one mushroom button, up to 4 small buttons, an RS422 jack and 2 optically isolated inputs in an ABS plastic enclosure.
- KP205A – Keypad with 8 buttons and a knob with RJ11 jacks mounted on a flush mount metal plate.
- KP205A_GC – Keypad with 8 buttons and a knob, RJ11 jacks and 8 ground closure inputs mounted on a flush mount metal plate.
- KP215A – Keypad with 8 buttons and a knob, RS422 jacks and 2 optically isolated inputs mounted on a flush mount metal plate.
- KP219A – Keypad with 18 buttons and a knob with RS422 connectors in a metal enclosure.
- KP219A-RF2 – Keypad with 18 buttons and a knob with built in wireless transmitter and one RS422 input in a metal enclosure.
- KP03A – Keypad with 4 user configurable buttons in a surface mount metal enclosure. Connects to the RSSR input on the timer/display.
- OC002A – Keypad with 2 user configurable buttons and 2 optically isolated inputs in a surface mount metal enclosure. Connects to the RSSR input on the timer/display.
- OC004B – Interface module with 4 optically isolated inputs in an ABS plastic enclosure. Connects to the RSSR input on the timer/display.
- You can provide your own buttons or connect your machine outputs directly to the RSSR inputs.
- You can connect a PLC, Crestron, AMX or any other device with a serial port to control the various functions of the Timekeeper™ timer/display.



Connecting multiple Timekeeper™s together

When multiple units are connected together, only one unit may become the controlling unit. The rest of the units become remote displays.

- The Timekeeper™ defaults to remote display mode at power up.
- Be sure to connect the units up such that the controlling unit's transmit port is connected to the receive unit's receive port.
- Once a button is pressed, the controlling unit changes to clock/timer mode.
- The controlling unit remains in timer mode until the power is turned off or a command is received that returns it to remote display mode.
- When connecting more than 2 units together, data on the transmit port of a remote display is echoed from the receive port.

When two units are connected together, in a specific configuration. Either unit can control all of the functions.

- Connect the transmit port of the first Timekeeper™ to the receive port of the second Timekeeper™.
- Connect the transmit port of the second Timekeeper™ to the receive port of the first Timekeeper™.
- Connect as many remote displays as you like to the first Timekeeper™.

- Configure the second Timekeeper™ to send key press commands. Set the “Time of day clock” setup parameter to “**CR**”.
- Now, either Timekeeper™ will operate all timer functions.

Additional operating instructions

Standard Momentary Controls

- **RESET** – Timer Reset
- **START** – Timer Start/Stop
- **SELECT** – Select between setting hours / minutes / seconds.
- **MODE** – Change to Count Up, Count down.
- **CLOCK** – Change to time of day clock mode.
- **PRESET** – Recall stored settings.
- **HISTORY** – Recall the 16 most recent counter or timer values (if this option is ordered).

Standard Press-and-Hold Controls

- **RESET** – Store power up settings (if this option is ordered).
- **START** – Set special timer mode or set button delay for remote inputs
- **SELECT** – Set warning times or counter scale factor.
- **MODE** – Change the beeper mode.
- **CLOCK** – Set the time of day clock.
- **PRESET** – Store settings.
- **HISTORY** – Not used.

Clock Mode

- Press the clock button to enter the clock mode. The Hours:Minutes:Seconds in 24 hour mode will be selected.
- Press the clock button again to display Clock Minutes:Seconds.
- Press the clock button again to display Hours:Minutes:Seconds in 12 hour mode.

NOTE: On a timer with only 4 digits, only the hours and minutes will be displayed. On a timer with 6 digits, the hours, minutes and seconds will be displayed.

The remote displays are updated once per minute with the correct time of day.

Device control Outputs

- Optional Relay Control signal (BEEP). Activated whenever the timer reaches time zero. Beep relay.

Front panel Led definitions – TMR221 models only

- Lower Left side - ON=Beep on OFF=Beep off
- Middle Left side - ON=Count up OFF=Count down
- Upper Left Side - ON=PM OFF=AM
- Lower Right side - ON=RED indicator, Time is up
- Middle Right Side - ON=YEL indicator, Yellow warning (“Wrap-it-up” time)
- Upper Right Side - ON=GRN indicator, Time is running
- Above Clock Button - RED=Time set mode, GRN=No sync signal, BLINKING GRN=SYNC**

**NOTE: See section on SYNC for more details.

Dimming the display

Not supported on all models. The dimmer value in the range 0 to 99 provides several distinct brightnesses, where 0-3 is the lowest brightness, and 96-99 is the highest brightness.

Note: Some models have 25 distinct levels while other models have only 4 or 10 distinct brightness levels.

Remote Ground Closure Inputs

The remote ground closure inputs are user configurable. The default functions for these inputs are described here. See the MSETUP configuration setting parameter for alternate functions for these inputs.

The timer can be started, stopped or reset by remote control. Grounding the respective signal activates the function. Typically the signals are grounded by pressing buttons on remote units. Notice that inputs IN2 and IN3 are dual function. They operate differently depending on whether the display is in timer mode or Tallye mode:

- IN1 – Changes the display to timer mode. Starts the timer.
- IN2 – In timer mode, stops the timer.
- IN2 – In Tallye mode, decrements the tally count by the scale factor (default 1).
- IN3 – In timer mode, resets the timer values to the initial preset values.
- IN3 – In Tallye mode, sets the tally count to zero. Reset does not stop the timer.
- IN4 – Changes the display to Tallye mode. Increments the tally count by the scale factor (default 1).



The KP03A or OC002A keypads can be configured to use the inputs you specify. Remove the rear cover of the KP03A or OC002A and configure the jumpers the way you desire.



Common configurations.

One common configuration used the keypad to control the timer functions.	Another common configuration used the keypad to control the counter (Tallye) functions.
<ul style="list-style-type: none"> ● Button 1 = IN1 Timer Start. ● Button 2 = IN2 Timer Stop. ● Button 3 = IN3 Timer Reset to zero. 	<ul style="list-style-type: none"> ● Button 1 = IN4 Counter Increment. ● Button 2 = IN2 Counter Decrement. ● Button 3 = IN3 Counter Reset to zero.
Typical Applications. <ul style="list-style-type: none"> ● Count up timer. ● Sporting events. ● Production timing. ● Event timing. 	Typical Applications. <ul style="list-style-type: none"> ● Production counting. ● Cycle counting. ● Take-a-number systems. ● Score keeping.

Activating one of the inputs at a time

IN1 – If the unit is not in timer mode, puts the unit into timer mode. If the unit is in timer mode and the timer is not running, starts the count up timer and increments the counter. If the unit is in timer mode and the timer is running, freeze the display for several seconds to display the lap time. The count up timer keeps running. IN1 has the ability to operate as a maintained or momentary ground closure. If IN1 is closed and held closed, the timer continues to run. When IN1 is released, the timer pauses.

Alternate functions for IN1. See the MSETUP configuration parameter for enabling the selected function.

- START_LAP_UTMR. Triggering IN1 starts the timer. Triggering IN1 while the timer is running (the timer continues to run) freezes the display for several seconds to display the lap time.
- RUN_PAUSE_TMR. Triggering IN1 starts the timer. Triggering IN1 while the timer is running pauses the timer.
- RESET_START_TMR. Triggering IN1 resets and starts the timer. Triggering IN1 while the timer is running resets and starts the timer again.
- RESET_START_STOP_TMR. Triggering IN1 resets and starts the timer. Triggering IN1 while the timer is running stops the timer.

IN2 – If the unit is in timer mode and the timer is running, stops the count up timer. If the timer is stopped, displays the lap time for the previous lap or displays the time from the previous run. If the unit is in counter mode, decrements the counter.

IN3 – If the unit is in timer mode, resets the count up timer to zero. If the timer is running, it continues to run from zero. If the unit is in counter mode, resets the counter to zero.

Alternate functions for IN3. See the MSETUP configuration parameter for enabling the selected function.

- RESET. Triggering IN3 resets the timer.
- RECALL stored setting. Triggering IN3 recalls stored setting 1.
- IN3 has the ability to operate as a maintained or momentary ground closure. If IN3 is closed and held closed, the timer continues to run. When IN3 is released, the timer pauses.

IN4 – If the unit is not in counter mode, put the unit into counter mode. If the unit is already in counter mode, increment the counter.

Activating more than one of the inputs at a time (LEGACY mode)

These functions operate in legacy mode only. These functions are disabled if the MSETUP setting is not in legacy mode.

IN1,IN2 – Run-Pause mode. If the unit is not in timer mode, puts the unit into timer mode. If the unit is in timer mode and the timer is not running, starts or continues the count up timer and increments the counter. If the unit is in timer mode and the timer is running, pauses the timer.

IN1,IN3 – Reset and Start, Stop mode. If the unit is not in timer mode, puts the unit into timer mode. If the unit is in timer mode and the timer is not running, resets, then starts the count up timer and increments the counter. If the unit is in timer mode and the timer is running, stops the timer.

IN1,IN2,IN3 – Two lap mode. Reset and Start, Lap Display, Stop mode. If the unit is not in timer mode, puts the unit into timer mode. If the unit is in timer mode and the timer is not running, resets, then starts the count up timer and increments the counter. If the unit is in timer mode and the timer is running, freezes the display for several seconds to display the lap time. The count up timer keeps running. If the unit is in timer mode and the timer is running and the lap time was displayed once, stops the timer.

IN3,IN4 – Sets the counter to the last preset value. Turn the **Knob** to set the timer preset value. The **Select** button selects between setting the upper, middle or lower set of counter preset values. Generally this function occurs by pressing the remote Counter **Up** and Counter **Reset** buttons at the same time.

IN1,IN4 – Beep the horn. Activates the beeper.

IN2,IN3 – Manually select the Red-Yellow-Green indicator. Each press cycles the Red or Yellow or Green indicator on or turns all three indicators off.

Optional: This configuration may be enabled by ordering the USE_BTN4_MANUAL_RYG option.

IN4 – Manually select the Red-Yellow-Green indicator. Each press cycles the Red or Yellow or Green indicator on or turns all three indicators off.

Remote command “KPJ – Manually select the Red-Yellow-Green indicator. Each press cycles the Red or Yellow or Green indicator on or turns all three indicators off.

Optional: This configuration may be enabled by ordering the USE_BTN3_IS_RECALL1 option.

IN3 – Recalls stored setting 1. Whatever settings that are stored into stored setting 1 are loaded.

Button Delay on remote inputs

In some situations it is best to ignore inputs for some period of time after the initial triggers.

Some examples:

- In a horse race, a horse starts a timer by crossing a photo beam, but then its tail might generate an extraneous trigger as it also crosses the beam.
- Counting clear CD cases using a photo beam, which may incorrectly detect reflections or transparent portions of the CD case as additional unit counts.
- At the start of a race, a photo beam detects the large engine on a drag racing “funny car”, but then the opening behind the engine allows it to generate a false trigger between the engine and the firewall that follows.

If you set the delay to 2.3 seconds, the respective input is ignored for 2.3 seconds after the initial trigger.

To change the button delay:

- Press and hold the **Test** button.
- Within 1 second, press the **Test** button eight more times to select the button delay for IN1. The display will show "**1-00**".
- Turn the **Knob** to change the selected button delay value.
- Press the **Select** button to advance to the button delay for IN2. The display will show "**2-00**".
- Turn the **Knob** to change the selected button delay value.
- Press the **Select** button to advance to the button delay for IN3. The display will show "**3-00**".
- Turn the **Knob** to change the selected button delay value.
- Press the **Select** button to advance to the button delay for IN4. The display will show "**4-00**".
- Turn the **Knob** to change the selected button delay value.

- OR -

- Wait 3 seconds, then press the **Test** button successively to select the desired button delay configuration parameter.
- To exit, press any button that changes the display mode or turn the power off and then on again.

The new values are stored in permanent memory. When the power is turned off and on, the values will be remembered.

Counter mode

This unit contains a counter with a range of 0 to 999999

Trigger the counter remote input (IN4) to increment the counter. Trigger the counter remote input (IN3) to decrement the counter. Trigger the counter remote input (IN2) to reset the counter.

Setting Counter scale factors

When the scale factor is 1, each trigger of the counter remote input (IN3) increments or decrements the count by 1. For example, it may be better to count by lots or cases of product. If the lot size is 75, set the scale factor to 75. Each trigger of the Tallye input will count in lots of 75.

To set the scale factor:

- Press the Counter **Up** button (input IN4) to select the counter mode.
- Press and hold the **Select** button until the display changes.
- Turn the **Knob** to set the lower two digits (xx00-xx99)
- Press the **Select** button again.
- Turn the **Knob** to set the upper two digits (00xx-99xx)

These settings can be saved into EEPROM by pressing and holding the stored settings button.

A momentary press of the stored settings button will recall the saved values.

Counter preset value for counter count down mode

Connect Inputs IN3 and IN4 together to the same button. Each time the button is pressed, the counter is loaded with the preset value.

Each time the IN2 (count down) input, the count is decremented by the scale scale factor amount,

To load a preset value into the counter, perform the following steps:

- Press the counter UP/Reset input IN3,IN4 to select the counter mode.
- Turn the knob to set the middle two digits (xx00xx-xx99xx)
- Press the select button again.
- Turn the knob to set the upper two digits (00xxxx-99xxxx)
- Press the select button.
- Turn the knob to set the lower two digits (xxxx00-xxxx99)

Historical data capture

The most recent 16 events are captured and saved into EEPROM. Three types of events are captured:

- The *timer value* is captured if the unit is in the timer mode. The timer display must be in count up mode. Each time the count up timer is reset to zero, the value in the display is stored into the history EEPROM memory.
- The *counter value* is captured if the unit is in the counter mode. Each time the counter is reset, the value in the display is stored into the history EEPROM memory.
- The *score value* is captured if the unit is in the score keeper mode. Each time the score is reset, the value in the display is stored into the history EEPROM memory.

To display the contents of the history memory, press the **History** button. Each press of the **History** button will display successively older entries in memory. When the end of the history memory is reached, the display will Show "-----". Timer entries will have decimal points every two digits. Counter entries will not have any decimal points.

Remote Display mode

The remote display mode displays alphanumeric characters received on the serial port.

Alphanumeric character on Seven-Segment LED Displays

Due to the limitations of seven-segment LEDs, certain displays replace some alphabetic characters by a strange character. Those replaced characters (both upper and lower case) for those types of displays are: m, q and w.

Additionally, the “z” character on those displays appears as two parallel lines “||”, and the “k” character partially appears “|-”. The remaining characters appear only in their upper or lower case form in order to remain identifiable on the seven-segment LED displays.

In addition to alphanumeric characters, the seven-segment LED displays are also able to show the dash, space and period characters (“-”, “ ”, “.”). Any other characters not mentioned here may be ignored by the display, potentially causing the entire message to be ignored.

Rear panel buttons.

Your display may have none, one or two rear panel buttons. If your display has one rear panel button, it will be the **Test/Configuration** button.

- Press the **Test/Config** button to display one of several test patterns.
- Press and hold the **Test/Config** button to enter the configuration mode.

If your display does not have any rear panel buttons. You will still be able to make configuration changes.

- Press and hold the **Start** button until the display changes.
- Press and hold the **Start** button again until the display changes.
- You are now in the configuration mode.

If your display has two rear panel buttons, Button one will be the **Test/Configuration** button. Button two will be the **History** button.

- Press the **Test/Config** button to display one of several test patterns.
- Press and hold the **Test/Config** button to enter the configuration mode.
- Press the **History** button to display the history memory.

If your display has a built in battery and battery charger, in addition to the normal functions, these buttons will also perform the power ON and power OFF functions of the display.

- Press and hold the **Power ON/Test/Config** button to turn the power on.
- Press and hold the **Off/History** button to turn the power off.

Testing the unit.

Pressing the Test button successively advances through each of several diagnostic tests. These tests verify the operation of the unit. Each press of the test button selects one of the following displays.

- Scrolling Hello Message.
- Segment Test Pattern.
- All segments ON.
- Input signal test.

Scrolling Hello Message.

Press the Test button to display the scrolling "Hello" message. This message is also sent on the serial port. Observe that the message "Hello" scrolls across the display every few seconds.

Segment Test Pattern.

Press the Test button again to display the segment test pattern sequence. Observe the display. The segments should light in the sequence as described below.

segment a on;
segment a-b on;
segment a-b-c on;
segment a-b-c-d on;
segment a-b-c-d-e on;
segment a-b-c-d-e-f on;
segment a-b-c-d-e-f-g on;
segment a-b-c-d-e-f-g-dp on;

All segments ON test.

Press the Test button again to turn all segments on. Verify that all segments are lit. Also verify that either the decimal points or colons are lit depending on hardware configuration.

Input signal test.

Press the Test button again to enable the input signal test. Press each of the buttons, Activate each of the remote inputs.

Turn the knob both clockwise and counterclockwise. Numeric values should appear on the display as shown in the following table. Two dashes will scroll across the display along with some values depending on the state of the various inputs.

Display Value	Description
<i>A</i>	Button 1
<i>B</i>	Button 2
<i>C</i>	Button 3
<i>D</i>	Button 4
<i>E</i>	Button 5
<i>F</i>	Button 6
<i>G</i>	Button 7
<i>H</i>	Button 8
<i>0</i>	Remote Input 1
<i>1</i>	Remote Input 2
<i>2</i>	Remote Input 3
<i>3</i>	Remote Input 4
<i>4</i>	Rotary Encoder Knob or button A
<i>5</i>	Rotary Encoder Knob or button B
<i>6</i>	50Hz/60Hz Sync signal detected.
<i>7</i>	32,768Hz Internal Oscillator detected.

Example display. If the display shows “--*63A*”, this indicates that Button 1 is pressed, Remote Input 1 is active and 50Hz/60Hz Sync signal detected.

Configuration and Setup.

The setup procedure is normally performed at the factory when you order the product. Occasionally, you may need to make changes to the setup parameters. The setup parameters are summarized below.

- The **Timer Mode** determines whether the display shows Days, Hours, Minutes, Seconds or 100ths of a second.
- The **Mode Setup** affects the function of the remote inputs and other system functions.
- The **Beep** parameter affects the beep duration and beep mode.
- The **Unit Address** is used when receiving communications from other devices. Range 0-31.
- The **Extended unit address** has a range of 000 to FFF and is used with the serial communications port.
- The **SERCMD** determines the number of digits transmitted on the serial communications port to a remote display.
- **Time of day clock and remote control** functions.
- **Baud rate** of the serial communications port. 1,200 to 115,200.
- **Button Delay** for the remote inputs IN1, IN2, IN3 and IN4.

There are several ways to change the configuration settings.

Use the **Test/Config** button on the rear of the unit.

- Use the **Test/Config** button on the rear of the unit. Press and hold the **Test** button until the display changes to enter the setup mode.
- Within one second, press the **Test** button successively to advance through the various settings.
- Wait 2 seconds and press the **Test** button successively to change the value or Turn the **knob** to change the value.
- Some models have a second button marked **B**. The **B** button will decrement the value, The **Test** button increments the value.

Use the timer **Start** button on the front panel or remote keypad depending on model.

- If you have a remote key pad with a Timer **Start** button, to enter the setup mode, press and hold the **Start** button until the display changes. The display will show “-**U**”.
- Press and hold the **Start** button again until the display changes. The display will show “**U..R**”.
- Press the **Select** button to step through the various settings.
- Turn the **knob** to change the value.

Select the timer display mode

This procedure selects whether the count up timer display shows hours, minutes, seconds or fractions of a second.

- Press and hold the **Test** button.
- Turn the **Knob** to change the selected configuration value.
- OR -
- Wait 3 seconds, then press the **Test** button to increment the selected parameter. The display shows a value representing the timer mode
-

Mode	Count Down	Count Up 8 Digit Display	Count Up 6 Digit Display	Count Up 4 Digit	Description
		Knob defaults to setting seconds for modes 1, 2 and 2.			
U..0	SS SS SS	SS.SS.SS.FF	SS SS.FF	SS.FF	Seconds .100ths
U..1	SS SS SS	SS SS SSS.F	SS SSS.F	SSS.F	Seconds .Tenths
U..2	SS SS SS	SS SS SS SS	SS SS SS	SS SS	Seconds
		Knob defaults to setting hours for modes E, J and K. Knob defaults to setting days for mode L. Knob defaults to setting minutes for other modes.			
U..3	MM MM:SS	MM MM:SS.FF	MM:SS.FF	SS.FF	Minutes :Seconds .100ths
U..4	MM MM:SS	MM MMM:SS.F	MMM:SS.F	M:SS.F	Minutes :Seconds .Tenths
U..5	MM MM:SS	MM MM MM:SS	MM MM:SS	MM:SS	Minutes :Seconds
U..6	MM MM:SS	MM MM MMM:S	MM MMM:S	MMM:S	Minutes :Tens of Seconds
U..7	MM MM MM	MM MM MM MM	MM MM MM	MM MM	Minutes
U..8	HH:MM:SS	HH:MM:SS.FF	MM:SS.FF	MM:SS.FF	Hours :Minutes :Seconds . 100ths
U..9	HH:MM:SS	HHH:MM:SS.F	H:MM:SS.F	M:SS.F	Minutes :Tens of Seconds
U..A	HH:MM:SS	HH HH:MM:SS	HH:MM:SS	MM:SS	Hours :Minutes :Seconds
U..B	HH:MM:SS	HH HHH:MM:S	HHH:MM:S	H:MM:S	Hours :Minutes :Tens of Seconds
U..C	HH HH:MM	HH HH HH:MM	HH HH:MM	HH:MM	Hours :Minutes
U..D	HH HH:MM	HH HH HHH:M	HH HHH:M	HHH:M	Hours :Tens of Minutes
U..E	HH HH HH	HH HH HH HH	HH HH HH	HH HH	Hours
U..F	HH:MM:SS	DD:HH:MM:SS	HH:MM:SS	MM:SS	Days :Hours :Minutes :Seconds
U.10	HH:MM:SS	DDD:HH:MM:S	D:HH:MM:S	H:MM:S	Days :Hours :Minutes :ten of Seconds
U.11	DD:HH:MM	DD DD:HH:MM	DD:HH:MM	HH:MM	Days :Hours :Minutes
U.12	DD:HH:MM	DD DDD:HH:M	DDD:HH:M	D:HH:M	Days :Hours :Tens of Minutes
U.13	DD:HH:MM	DD DD DD:HH	DD DD:HH	DD:HH	Days :Hours
U.14	DD:HH:MM	DD DD DDD: H	DD DDD: H	DDD: H	Days: Tens of Hours
U.15	DD DD DD	DD DD DD DD	DD DD DD	DD DD	Days
U.16	SS SS SS	SS SS S.TTT	S SS.TTT	S.TTT	Seconds. Thousandths of a second
NOTE: When mode 15 is selected, the days timer rolls over at midnight.					

- To exit, press any button that changes the display mode or turn the power off and then on again.

Select the MSETUP mode

This procedure selects whether the count up timer display shows hours, minutes, seconds or fractions of a second.

- Press and hold the **Start** button until display changes.
- Within 1 second, press the **Start** button until the display changes (selects the MSETUP mode configuration parameter). The display will show "L7".
- Turn the **Knob** to change the selected configuration value.
- OR -
- Wait 3 seconds, then press the **Start** button to increment the selected parameter. The display shows a value representing the timer mode

The following table describes the various options. Multiple options can be selected by adding the respective numbers together. The numbers are represented in ASCII HEX notation. Range 0, 1, 2, 3, 4, 5, 6, 7, 8, 9, A, B, C, D, E, F. For example, 8 plus 2 = 10 or "A" in ASCII HEX notation.

L-Value	Description
L00	Default to timer to count down mode.
L01	Default to timer to count up mode.
L00	Remote input 1 is default configuration. See documentation on remote inputs for details.
L02	Remote input 1 is START-LAP Up Timer. Both the split time and the lap time is stored into the history memory.
L04	Remote input 1 is START-SPLIT Up Timer. Both the split time and the lap time is stored into the history memory.
L06	Remote input 1 is RUN-PAUSE Up Timer
L08	Remote input 1 is RESET-START Timer.
L0A	Remote input 1 is RESET-START-STOP Timer.
L00	Remote input 3 is RESET timer.
L10	Remote input 3 is RECALL stored setting 1.
L20	Remote input 3 is COUNTER2.
L30	Remote input 3 is COUNTER23
L00	The Green indicator is on when the timer is started; The Red indicator is on when the timer reaches zero.
L40	The Red indicator is on when the timer is started; The Green indicator is on when the timer reaches zero.

Beeper duration setup

- Press and hold the **Test** button.
- Within 1 second, press the **Test** button two more times to select the beeper mode configuration parameter. The display will show "-7".
- Turn the **Knob** to change the selected configuration value.
- OR -

- Wait 3 seconds, then press the **Test** button successively to select the desired beeper duration.
- The beep duration is represented as 1= 0.4 second; 2=0.8 second; 3=1.2 second; etc. Range: 0-7.
- To exit, press any button that changes the display mode or turn the power off and then on again.

Unit Address setup

The display can be set up to respond to an address-specific command. The address-specific commands provide the same functionality as the general commands, but allow control of which display unit will respond when several displays are connected together. A unit can be set to one address within the range 0 through 9, and A through O. The address range is 0 to 1F in ASCII HEX notation. See the programming manual for more details on using this address command.

Example corresponding commands are "KA0n. The address range is 0 to 1F in ASCII HEX notation where 0="KA0x; 10="KA@x; 11="KAAx and 1F="KAOx.

Example:

Two units are connected to the same serial port. One unit is configured for address '0', and the other is configured as address '1'. The first unit ('0') responds to a "KADH command, but not the second unit ('1'). The second unit ('1') responds to a "KATW command, but the first unit does not.

Example corresponding commands are "L0xxxx through "L9xxxx and "LAxxxx through "LOxxxx. The address range is 0 to 1F in ASCII HEX notation where 0="L0xxxx; 10="L@xxxx; 11="LAxxxx and 1F="LOxxxx.

Example:

Two units are connected to the same serial port. One unit is configured for address '0', and the other is configured as address '1'. The first unit ('0') responds to a "LOHELLO command, but not the second unit ('1'). The second unit ('1') responds to a "LIWORLD command, but the first unit does not.

To configure the address for a unit:

- Press and hold the **Test** button.
- Within 1 second, press the **Test** button three more times to select the unit address configuration parameter. The display will show "AAA".
- Turn the **Knob** to change the selected configuration value.

- OR -

- Wait 3 seconds, then press the **Test** button to select the desired unit address.
- To exit, press any button that changes the display mode or turn the power off and then on again.

Extended Unit Address setup

The display can be set up to respond to an address-specific command. The address-specific commands provide the same functionality as the general commands, but allow control of which display unit will respond when several displays are connected together. A unit can be set to one address within the range 0 through 9, and A through F. The address range is 000 to FFF in ASCII HEX notation for a total of 4096 possible addresses.

Example corresponding commands are "A000 through "AFFF. The address range is 000 to FFF in ASCII HEX notation. See the programming manual for more details on using this address command.

Example:

Two units are connected to the same serial port. One unit is configured for address '0', and the other is configured as address '1'. The first unit ('0') responds to a "A000 command, but not the second unit ('1'). The second unit ('1') responds to a "A001 command, but the first unit does not.

To configure the address for a unit:

- Press and hold the **Test** button.

- Within 1 second, press the **Test** button four more times to select the unit address configuration parameter. The display will show "**HHH**".
 - Turn the **Knob** to change the selected configuration value.
- OR -
- Wait 3 seconds, then press the **Test** button to select the desired unit address.
 - To exit, press any button that changes the display mode or turn the power off and then on again.

Serial Data Output setup

- Press and hold the **Test** button.
 - Within 1 second, press the **Test** button five more times to select the serial data output configuration parameter. The display will show "**EE**".
 - Turn the **Knob** to change the selected configuration value.
- OR -
- Wait 3 seconds, then press the **Test** button successively to select the desired number of digits to output on the serial port.
 - The most common values are 2 through 8 digits. This should be set to match the connected remote displays. Range 0 to 15 digits.
 - To exit, press any button that changes the display mode or turn the power off and then on again.

Time of Day Clock and serial data output setup

- Press and hold the **Test** button.
 - Within 1 second, press the **Test** button six more times to select the time of day clock setup configuration parameter. The display will show "**CCC**".
 - Turn the **Knob** to change the selected configuration value.
- OR -
- Wait 3 seconds, then press the **Test** button successively to select the desired time of day clock setup duration.
 - To exit, press any button that changes the display mode or turn the power off and then on again.

The following table describes the various options. Multiple options can be selected by adding the respective numbers together.

Value	Description
C00	Default to the 24 hour mode when the clock button is pressed.
C01	Default to the 12 hour mode when the clock button is pressed.
C02	Default display is a time of day clock in 12 hour mode. Disables sending DSP, "L0, "TY, or TME commands on the serial port.
C03	Default display is a time of day clock in 24 hour mode. Disables sending DSP, "L0, "TY, or TME commands on the serial port.
C00	While in the time of day clock mode, with 4-digit displays, send HH:MM or MM:SS (4 digit) DSP or "L0 commands on the serial port.
C04	While in the time of day clock mode, always send HH:MM:SS (6 digit) DSP or "L0 commands on the serial port.
C08	Default to remote mode.
C0A	Remote Control Mode. This mode is used to remotely control another timekeeper connected to this unit. Pressing a button on this unit generates "KPn commands that are sent to a remotely connected

Value	Description
	timekeeper. The remote timekeeper sends RLY, DSP or “L0 responses to this unit.
C00	Send "Lnxxxx commands on the serial port. Where n is the unit address.
C10	Send DSPxxxx commands on the serial port.
C02	Process "KPN commands locally.
C12	Do not Process "KPN commands locally. Echo "KPN commands back out on the serial port.
C20	90 second power off delay. When powered by DC, the display goes dark when the timer is not running or no data is being received. When powered by AC or receiving a 50/50Hz sync signal, this option has no effect.
C40	All received serial data characters are echoed out on the transmit serial port. This unit does not transmit RLY, DSP or “L0 commands.

Baud rate setup

- Press and hold the **Test** button.
 - Within 1 second, Press the **Test** button seven more times to select the RS232 serial port baud rate. The display will show "**67**".
 - Turn the **Knob** to change the selected configuration value. (Cannot be changed from a remote keypad)
- OR -
- Wait 3 seconds, then press the test button to select the desired baud rate. The range is 0 to 7 corresponding to 0=1,200, 1=2,400, 2=4,800, 3=9,600, 4=19,200, 5=38,400, 6=56,800, 7=115,200 baud.
 - To exit, press any button that changes the display mode or turn the power off and then on again.

NOTE: Most Alzatex products default to 2,400 baud. The baud rate should be set to "**67**" in most situations.

Button Delay setup for IN1, IN2, IN3 and IN4

The purpose of this setting is to eliminate false triggers from the timer start button accidentally being triggered twice. For instance, if you are racing horses, The horses head starts the timer, but the swishing of the tail should be ignored. A bicycle starts the timer, but the openings in the frame should be ignored. If you are counting CD cases, the case increments the count, but the clear portions of the case should be ignored.

The RSSR port has 4 inputs. See the section on remote inputs for details of the function of these inputs.

- Press and hold the **Test** button.
 - Within 1 second, Press the **Test** button eight more times to select the button delay setup. The display will show "0-00".
 - Turn the **Knob** to change the desired button delay value.
- OR -
- Wait 3 seconds, then press the test button to select the desired baud rate. The range is 0 to 99 corresponding to 0=No delay, 1=0.1 second, 2=0.2 second, 10=one second, 50=five seconds.
 - To exit, press any button that changes the display mode or turn the power off and then on again.

NOTE:.

Displaying the firmware version number

- Press the **Config** button. As the button is being pressed, a 2 digit number will appear on the display. This is the firmware version number.

Remote time of day setting

When the time of day is being set, the TME command is generated when the time set mode is exited. This is useful when setting the time of day in the remote displays. When multiple timers and/or displays are connected together, the time of day information is automatically passed from the controlling unit to all the slave units.

It may be desirable for the remote units to display the time of day when not being used for other purposes.

To cause the remote units to remain in the time of day clock mode while the controller is disconnected from the system, perform the following steps.

- Make sure the time of day clock is set correctly.
- Press the clock button to cause the time of day to appear in the display.
- Disconnect the controlling unit from the system.
- All the remote displays will display the time of day.

To cause the remote units to go dark while the controller is disconnected from the system, perform the following steps.

- Press the reset button to cause the timer or counter to appear in the display.
- Disconnect the controlling unit from the system.
- All the remote displays will display go dark after a few seconds.

Technical Description

This section contains information that might be useful for system designers, system integrators and installers.

Power up

When the unit is first powered up all the LEDs come on and the scrolling message "Hello" appears in the display.

NOTE: If the "Hello" message appears, but does not scroll, the firmware is a variation not described by this manual.

NOTE: If you have stored a power up preset, the Hello message will not appear.

Connectors

The Timerkeeper™ unit will have some or all of the following connectors. Refer to the data sheet for the specific model for details.

- RJ11 serial data connectors.
- RJ11 ground closure input connector.
- RJ45 serial data connectors.
- Power Connector

RJ11 Serial Data Connectors

RJ11 accessory connectors:

- RJ11 Receive Jack, marked "RX" or "IN". This connector receives data from other units on DATA 1 and transmits data on DATA 3.
- RJ11 Transmit Jack, marked "TX" or "OUT". This connector transmits data to other units on DATA 1 and receives data on DATA 3.
- The DATA 2 pin on the and RJ11 carries the 50/60Hz sync signal.
- Using a 4 conductor modular cord, the RJ11-TX connector is typically used for transmit data. RJ11-RX connector is typically used for receive data.
- Using a 6 conductor modular cord, the RJ11-TX is typically used for transmit data on DATA 1 and receive data on DATA 3. The RJ11-RX connector is typically used for receive data on DATA 1 and transmit data on DATA 3.

Timekeeper™ Serial Data Input and Output on the RJ11 jacks

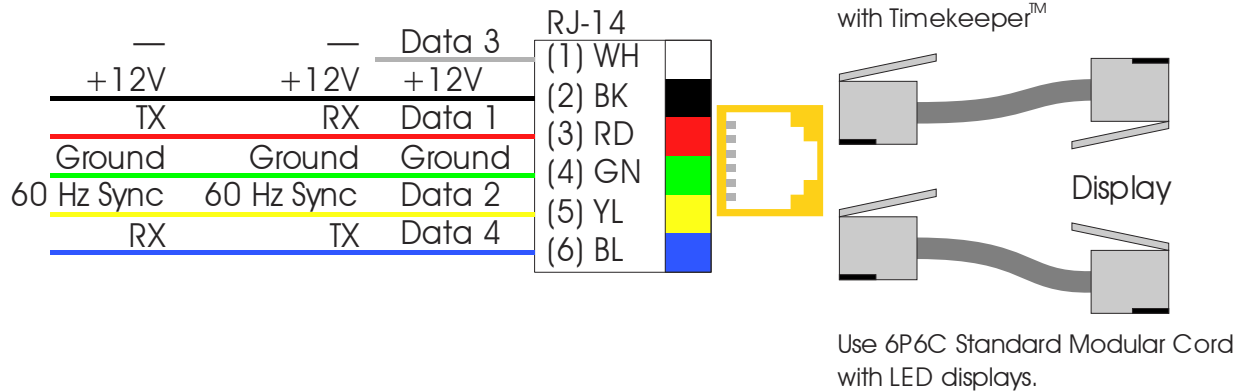

RJ11 Ground Closure Input Connector

RJ11 remote control timer RSSR jack with ground closure inputs:

- RJ11 Ground Closure Jack, marked “RSSR”, with lines described in this document as “IN1,IN2,IN3,IN4”. See the connection diagram provided in the installation instructions for a particular unit. Buttons, readers, optical couplers, photo beams, hall-effect sensors, or more line outputs may be connected to these inputs. This connector also has an output to provide external power to operate external sensors.

Timekeeper™ Remote Ground Closure Inputs Setup as a Counter

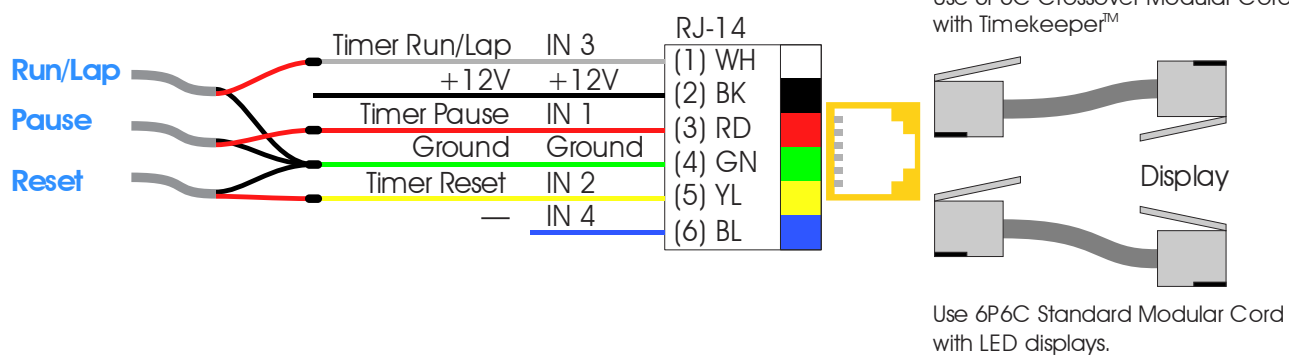
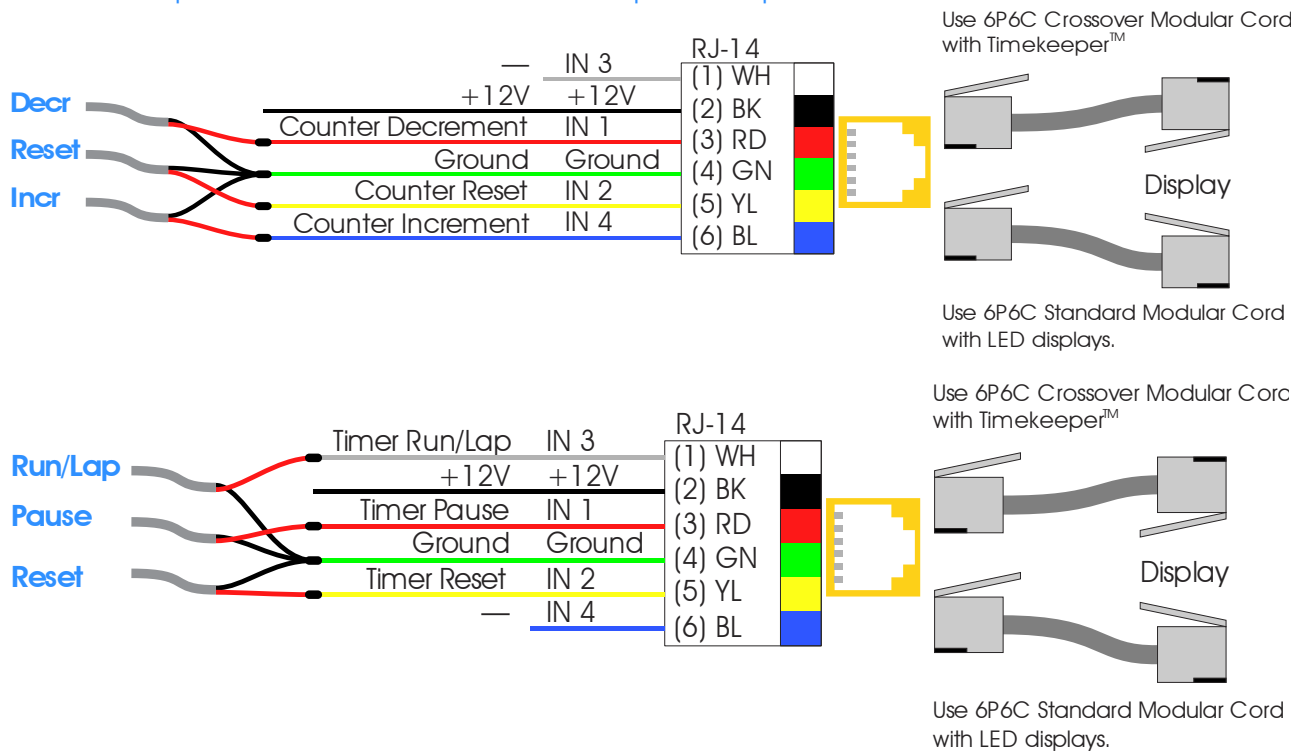

RS422 Serial Data Connectors (RJ45)

The Timerkeeper™ unit will have none, some or all of the following RJ45 connectors:

- RJ45 Receive Jack, marked “RX422” or “IN”.
- RJ45 Transmit Jack, marked “TX422” or “OUT”.

In the single channel configuration, There is a single RS422 data channel. The other 3 pairs carry power. If you do not install the jumpers, then the Green pair is not used.

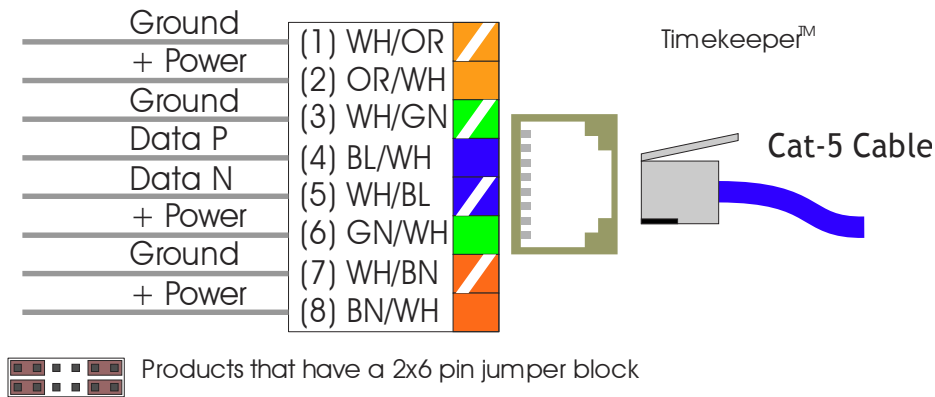

In the dual channel configuration, There are two RS422 data channels. One pair transmits data while the other pair receives data. The other 2 pairs carry power.

- The TX422 Jack will transmit data on the Data 1 pair and receive data on the DATA 2 pair
- The RX422 Jack will receive data on the Data 1 pair and transmit data on the DATA 2 pair

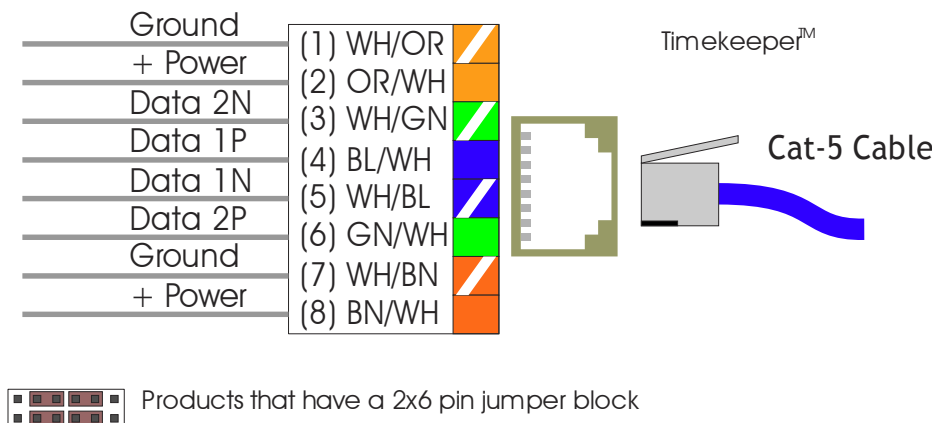

The RJ45 connectors are configured as follows:

- Pair 1 (Blue/White) is used for RS422 data transmission/reception.
- Pairs 2,3,4 (Orange/White, Green/White and Brown/White) are used to carry 12VDC power.
- In some cases, Pair 2 (Green/White) are used for data in the reverse direction. These units have special configuration jumpers to change the function of pair 2.

Power Distribution

All of the connectors described above have 12VDC power input/output so that if one Timerkeeper™ is powered, all are powered. Keep in mind that larger displays require more power. The power supplies within a display unit has specific limitations. DO NOT overload the power supply. If you are powering a larger number of displays, Alzatex provides a **KT6X422A** or **KT8X422A** distribution module that permits multiple displays to be powered from a single source. With the use of these distribution modules, an unlimited number of displays may be connected in a single system.

Some models have only RJ11 connectors, while other models have only RJ45 connectors. Alzatex provides a **PS422A** module that can power up to 4 devices and converts from RJ11 to RJ45 interfaces. See the data sheet for details.

Alzatex also manufactures serial interface modules to convert data from RS422 or RJ11 to RS232C. These modules also have a built in power supply for powering timers and/or displays.

- The **PS1DB9B** interface adapter converts RJ11 data to RS232C.
- The **PS422DB9A** interface adapter converts RJ45 (RS422) data to RS232C.

See the connection diagram provided in the installation instructions for a particular unit.

- The power supply in the DSP017 and DSP221 series can drive up to a 0.75A load.
- The power supply in the larger sized displays/timers can drive up to a 2A load.
- Larger loads require a distribution module. Each distribution module can drive up to a 5A load when the 12VAC50VA wall transformer is used.
- Larger loads require a distribution module. Each distribution module can drive up to a 9A load when the SYM04 power supply is used.

Beeper and/or Relay Output

See the specific relay output applications on how these optional configurations are used:

- Run Relay. Some models have an NPN ground closure output. Specific models may be equipped with a relay with 2.5A or 5A dry contacts. The RUN relay option must be specified when ordering.
- Beep Relay. Some models have an NPN ground closure output. Specific models may be equipped with a relay with 2.5A or 5A dry contacts. The BEEP relay option must be specified when ordering.
- Beeper. Instead of or in addition to the relay, One or more beepers or loud sounders may be installed. The specific Beeper/Sounder option must be specified when ordering.

Wireless Communication

A wireless transceiver may be connected to most models. Any number of timers and displays may be connected together using wireless communication.

- The 2.4GHz wireless module is accepted in most countries.
- The 900MHz wireless module provides a longer range. (USA only)

A wireless receiver for a hand held keyfob may be connected to most models.

- Timer. The 3 button key chain transmitter provides timer start, stop and reset.
- Counter. The 3 button key chain transmitter provides counter increment, decrement and reset.

DC power status checking and the 50/60Hz SYNC signal

The unit will accept either 50Hz or 60Hz line frequencies. It will automatically detect which line frequency is being received. This feature only applies to models that the 50/60 Hz SYNC feature.

The AC/DC power status can be checked by observing the 60Hz SYNC signal. An oscilloscope or multi-meter will help when observing this signal. This signal will have one of the following states.

- Steady logic low indicates battery operation.
- Steady logic high indicates DC power applied.
- Pulsing at the 60 Hz rate indicates 60 Hz AC power applied.
- Pulsing at the 50 Hz rate indicates 50 Hz AC power applied.

Clock SYNC signal status monitoring system.

An indicator that visibly signifies whether or not the 50/60Hz sync is being received. In the timer mode, the PM LED is on permanently if no 50/60Hz sync is detected.

While in clock mode, the center colon reflects the same information as the clock LED. The clock LED will be used to indicate the status of the clock SYNC signal. When the clock LED is off, the unit is in the timer or tally mode.

No sync signal is being received.

- When the clock LED is on steadily, no sync signal is being received.
- In this mode the clock is the least accurate. In this mode, the clock has an accuracy of the internal crystal.

The 32KHz is generating the sync signal.

This is not available on all models.

- The clock LED flashes once every 2 seconds.
- When the clock LED is making very short flashes one per second, the internal 32KHz crystal is generating the SYNC signal.
- In this mode the clock is the much more accurate. In this mode, the clock has an accuracy of 20 parts per million.

External 50hz sync has been detected.

- The clock LED blinks on/off every 2 seconds.
- When the clock LED is on for two seconds, then off for two seconds, the timer is receiving a SYNC signal from a 50Hz AC line.
- In this mode the clock is the most accurate. The clock is as accurate as the AC line frequency. In most countries the accuracy is within five seconds per year.

External 60hz sync has been detected.

- The clock LED blinks on/off once per second.
- When the clock LED is on for one second, then off for one second, and continues to repeat this pattern, then the timer is receiving a SYNC signal from a 60Hz AC line.
- In this mode the clock is the most accurate. The clock is as accurate as the AC line frequency. In most countries the accuracy is within five seconds per year.

Timekeeper™ wiring diagram examples are available in separate documents.

See the specific application note that best fits your application.